

# Cable winch

## Flat bed loader HTD / HTS - EN

## General

Flat bed trailers can optionally be equipped with a hydraulically operated cable winch.

The cable winch can be operated manually or with radio remote control.

The cable winch consists of the following main components:

- Hydraulic motor
- Clutch / brake housing
- Cable drum
- Gearbox
- Hydraulic switch-over
- Manual operating lever
- Radio activation (Controller 8)
- Radio remote control

The towing vehicle must supply the cable winch with hydraulic fluid.

The radio operation requires a 12 V or 24 V power supply.

If the radio remote operation fails, the cable winch can be operated manually.

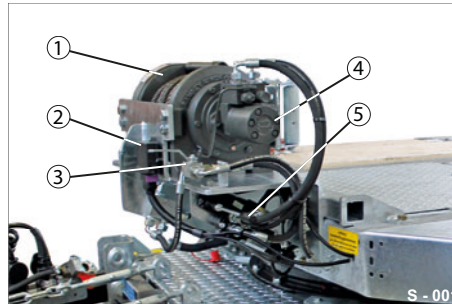

**Abb. 1** Cable winch (component)

- 1 Cable drum
- 2 Radio receiver / operation
- 3 Main switch, hydraulics supply
- 4 Hydraulic motor
- 5 Operating lever, manual

The cable winch for the flatbed centre pivot plate is installed in front of / in the centre of the elevated plateau.

The cable winch is attached on a sturdy frame (Abb. 2/13).

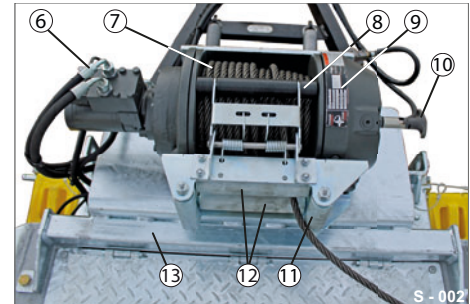

**Abb. 2** Cable winch (component)

- 6 Hydraulic lines / connections
- 7 Steel cable, D=13 mm, length approximately 33 m
- 8 Low pressure roller
- 9 Type plate / Warnings
- 10 Clutch lever, manual
- 11 Guide pulley, side
- 12 Guide pulley, top / bottom
- 13 Frame



The cable winch must only be used to pull up vehicles with wheels!

Any other application, e.g. pulling up loads without wheels (with tracks), lifting loads, pulling vehicles behind the trailer, transport of persons, etc. is prohibited!

## Technical data

Winch force max.	53.3 kN
Noise level max.	75 dB
Ambient temperature	- 28 °C to 60 °C
Weight (without cable / accessories)	approximately 135 kg

CABLE POSITION	1	2	3	4
	53.3 kN	44.6 kN	38.4 kN	33.7 kN
Cable length per POSITION*	6 M	13 M	22 M	33 M

\* with wire cable D=13 mm

**Tab. 1** Basic technical data



## WARNING

### Cable winch overload

Cable winches / cable / holder, etc. may break - Accident Risk!

- ▶ Do not overload the cable winch.  
Comply with the max. approved forces for the cable winches.
- ▶ Do not pull up loads without their own wheels, e.g. track vehicles.
- ▶ Observe the response from the cable and cable components while pulling up the load.

## Safety information / Warnings

The cable winch to pull up vehicles onto the load surface of the flatbed trailers is subject to machine directive 2006/42/EG.



Cable winches must be operated by trained personnel exclusively!



Persons operating the flatbed trailer must have read and understood the operating manual!



For information on correct operation of the drive-up ramps / loading ramps, read the operating manual for flatbed trailers.

All warning information is contained in the operating manual for flatbed trailers!

The following section contains additional information on dangers associated with the handling of cable winch.



Maintenance / servicing work on the cable winch may only be performed by qualified specialists in a specialist workshop!



Read and observe the safety notes from the manufacturer in the operating manual and on the cable winch!



Abb. 3 Type plate on the cable winch



Compliance with the items below is mandatory prior to and during the operation of the cable winch!

- Check to make sure the clutch lever is latched into position.
- Do not disengage the clutch with an applied load.
- Check to make sure that the cable drum has at least 2 cable coils.
- Check the condition of the unwound cable and hook. The cable must not have any tears / fraying / bends. The hook must not be deformed.
- Never attempt to guide the cable while pulling up a load.
- Never stay below / next to or on top of the load to be pulled.
- Stay at a safe distance to the vehicle and/or cable.
- Keep additional support personnel away from the danger zone.
- If a problem occurs, abort pulling up the load.



Abb. 4 Danger zones when pulling up loads / vehicles



Abb. 5 Danger zones when pulling up loads / vehicles

Specific warnings:

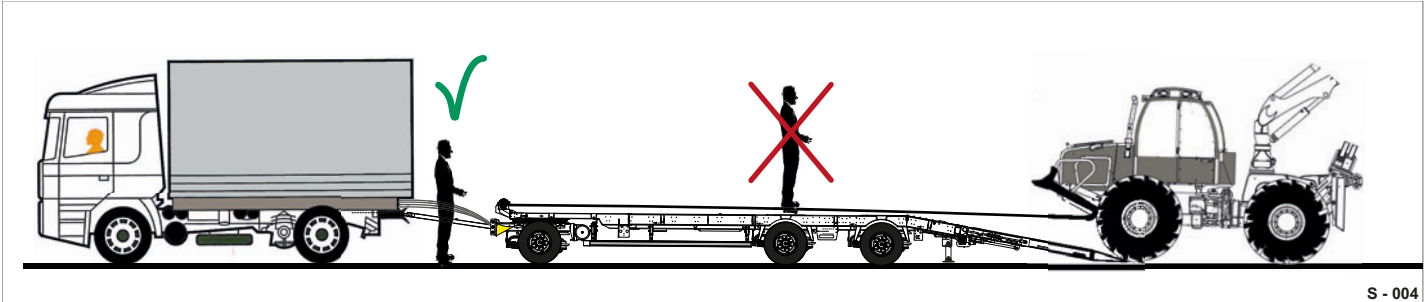

Keep away!

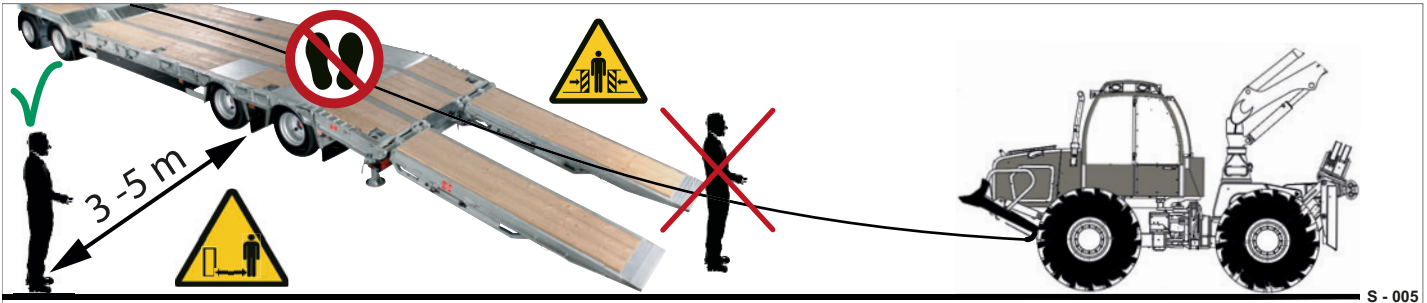

Rotating drums!



Moving loads!



Abb. 6 CORRECT: Pulling up a load straight



Abb. 8 Danger zones at the cable winch

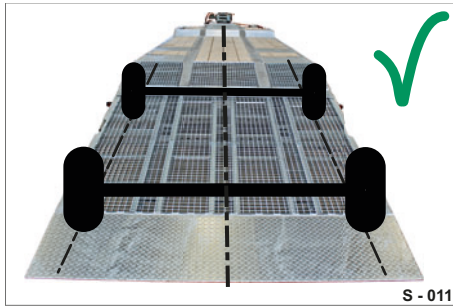

Abb. 7 WRONG: Pulling up a load at an angle

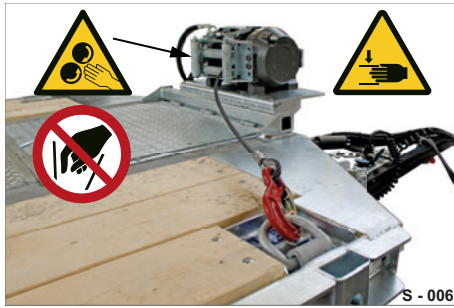

Abb. 9 Clutch lever is latched into position

**!** The load / vehicle must always be pulled up straight onto the loading surface - never at an angle from the side!

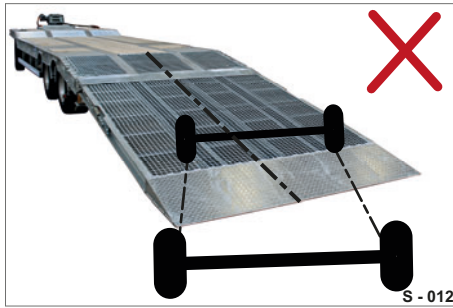
**!** The clutch must be engaged prior to operating the cable winch - clutch lever latched into position!  
The clutch lever must never be pulled out with an applied load!

**WARNING**

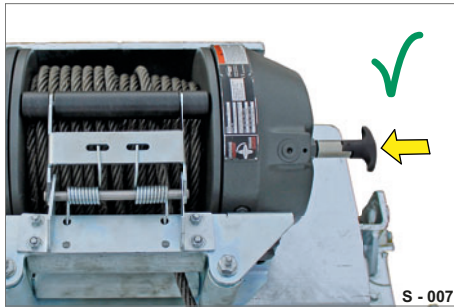
**Cable striking out**  
The cable may strike out to the side in the event of a tear and hit or whip you / personnel.

▶ Keep a safety distance to the trailer of at least 3 - 5 m when pulling the load up.

▶ Keep personnel away from the danger zone.

▶ When pulling up very heavy loads, hang a blanket, sheathing or canvas over the cable approximately 1.5 to 1.8 m behind the hook. This will buffer the recoil / lashing of the cable in the event of a break and minimize the risk of injury.





**DANGER**



**Crushing hazard between trailer and load**

You can be crushed between the frame of the vehicle and the load pulling up!

- ▶ Do not step between the trailer and the load to be pulled up.



- ▶ Keep a safety distance to the trailer of at least 3 - 5 m when pulling the load up.

- ▶ Observe the process and stop immediately if problems occur.

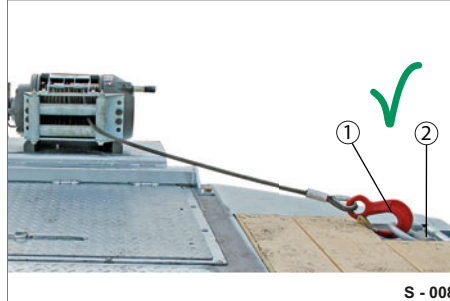

**Abb. 10** Cable parked

- 1 Hook
- 2 Lashing ring



**WARNING**



**Unsecured load**

The load may tip over / fall off the loading surface - crushing / hitting / accident danger!

- ▶ Secure the load at the appropriate lashing points.
- ▶ Never lash the load with the hooks of the cable winches - the cable winches are not designed for this.
- ▶ For example, park the cable / hook at a lashing ring.



**WARNING**

**Escaping hydraulic oil / lines under pressure**

Hydraulic oil escaping under pressure can cut through skin.

Hydraulic oil can cause skin irritation.

- ▶ Check the hydraulic lines for damage prior to operating the cable winches.
- ▶ Before performing maintenance work on the hydraulic system, check that the lines are depressurised and / or disconnected from the towing vehicle.



- ▶ Use



**WARNING****Moving loads**

Moving loads, e.g. vehicles, may tip over / fall down - danger of getting hit or crushed!

- ▶ Never step below or next to raised loads.
- ▶ Avoid excessive "Tipping Operation".
- ▶ Pull the load straight onto the loading surface, not at an angle.
- ▶ Always use the radio remote control to operate the cable winches. Manual operation is only permitted in the event of an emergency or radio remote control malfunction.

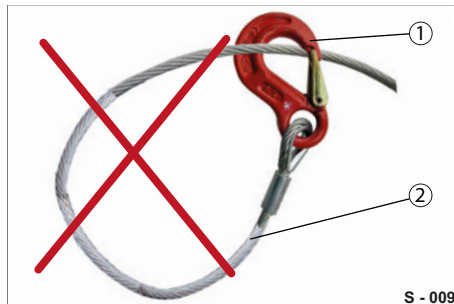

- ▶ Keep support personnel away from the danger zone. If necessary, interrupt the work.

**Abb. 11** Entangled cable

- 1 Hook
- 2 Cable

**WARNING****Using the cable as a sling**

The cable may be damaged and break - Danger of getting hit / accident risk!

- ▶ Always connect the load directly to the hook and/or use a separate nylon sling for this purpose.

**Abb. 12** Hook operation**WARNING****Putting a finger through the hook**

The finger can be sprained / ripped off by an unexpected movement!



- ▶ Use .
- ▶ Always touch the hook from the outside - never the inside.



## Establishing the hydraulics supply

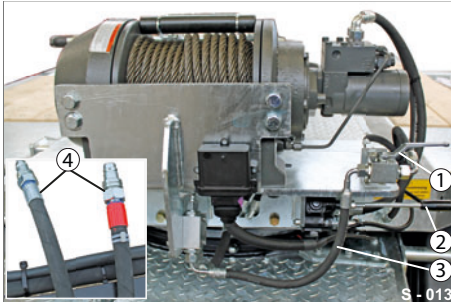

**Abb. 13** Switching the hydraulics distribution

- 1 Switch lever (valve)
- 2 Operating lever for manual operation
- 3 Hydraulic lines
- 4 Hydraulic supply lines

The hydraulic distribution must be switched over accordingly.

The tractor directly supplies the hydraulic motor of the cable winches with hydraulic oil.



If the hydraulic distribution is not set correctly, the cable winch will not function - no pressure build-up.

- ▶ Connect the hydraulic supply lines (Abb. 13/4) to the tractor.

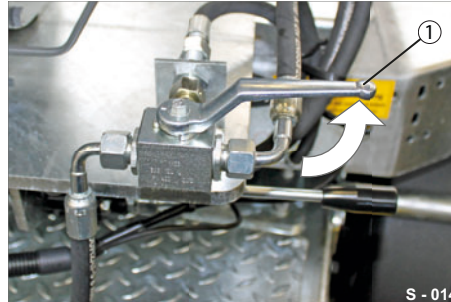

**Abb. 14** Setting for cable winch

- 1 Label

The switch lever (Abb. 13/1) must be switched for the corresponding hydraulic distribution (for the drive-up ramps / loading ramps or cable winch).

The label (Abb. 14/1) indicates the hydraulic distribution.

The valve will redirect the hydraulic oil accordingly.

- ▶ Check the position of the switch lever after establishing the hydraulic supply.

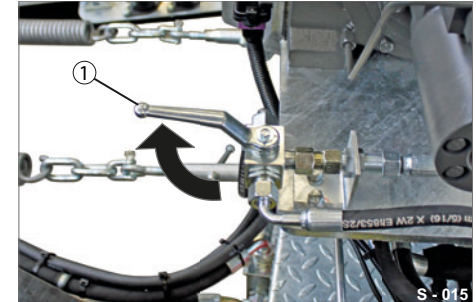

**Abb. 15** Setting for the loading wall

- 1 Switch lever, direction tongue

- ▶ Flip the switch lever (Abb. 15/1) into the direction of the tongue.

The hydraulic supply has been switched for the operation of drive-up ramps / loading ramps and/or supports.

## Connecting the power supply



Abb. 16 Trailer power supply

- 1 Voltage converter 12 V - 24 V

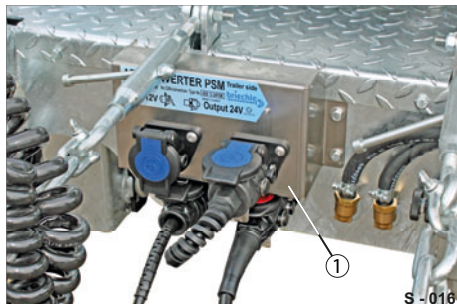

Abb. 17 Manual operation

- 1 Operating lever



Abb. 18 Radio remote control

- 1 Protective cover  
2 Status lights  
3 STOP button (red)  
4 START button (green)  
5 Buttons: UP - DOWN

The operation of the cable winches with the radio remote control requires a power supply of 12 V to 24 V.

The tractor supplies the power.

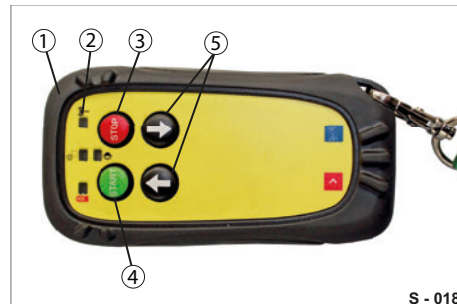

The connection must be established prior to operating the cable winches.



Read the flatbed vehicle operating instructions for the operation of the voltage converter.

## Manual emergency operation



The manual operation of the cable winches with operating levers should only be applied as an exception, e.g. in the event of a radio remote control malfunction.

- ▶ Press the operating lever (Abb. 17/1) up or down depending on the desired direction of rotation for the cable drum.



- ▶ Obtain help from a second person.

## Remote operation

The radio remote control is equipped with a safety to prevent unintended activation.

- ▶ To activate the radio remote control: First, press the STOP button (Abb. 18/3). Then press the START button (Abb. 18/4). Press the UP or DOWN button (Abb. 18/5).

## Technical data: EASY remote operation

Manufacturer	SISTEMATICA S.p.A.
Number of controls	2 to 6
Dimensions	(109 x 56 x 30) mm
Degree of protection	IP 67
Operating temperature	- 20 °C to + 70 °C
Supply	2 Batteries AAA Alkaline 1.5 V
Transmitter range	100 - 150 m in environment without interference



## Technical data: Remote receiver CONTROLLER 8

Manufacturer	SISTEMATICA S.p.A.
Frequency	ISM 868/915 MHz
Dimensions	(108 x 110 x 44) mm
Degree of protection	IP 66
Operating temperature	- 20 °C to + 55 °C
Supply	12 - 24 V DC +/- 10%
Total max. current	10 A



## Establish compressed air supply



**Abb. 19** Compressed air supply for trailer  
 1 Compressed air reservoir (below frame)

The valves for the operation of the cable winches are switched with compressed air.

Compressed air is supplied with the compressed air reservoirs.



The operating pressure for the valves must be at least 4 bar and cannot exceed 8.5 bar.  
 No operation with pressure below 4 bar.

The tractor must supply the trailer with compressed air to operate the cable winches.

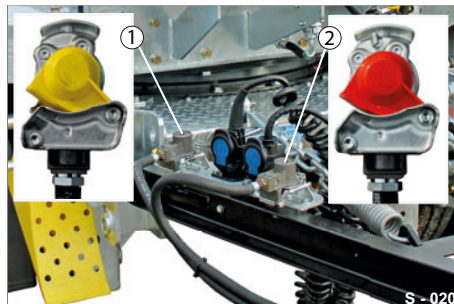

**Abb. 20** Compressed air supply lines  
 1 Compressed air brake (yellow)  
 2 Compressed air supply (red)

► Connect the supply lines for compressed air to the tractor.

## Preparatory work

Prerequisites:

- The trailer is properly coupled with the tractor and secured with the parking brake
- Hydraulic supply connected
- Compressed air supply connected
- Power connected
- Trailer for the load / vehicle to be pulled up parked straight for straight pull-up

The steps below must be taken in sequence:

- Drop / fold down the supports at the rear of the trailer
- Drop / fold down the loading wall / drive-up ramps
- Unwind the cable and check for damage at the same time
- Securely attach hooks / slings to the load / vehicle



Read the flatbed vehicle operating instructions for the operation of the components.

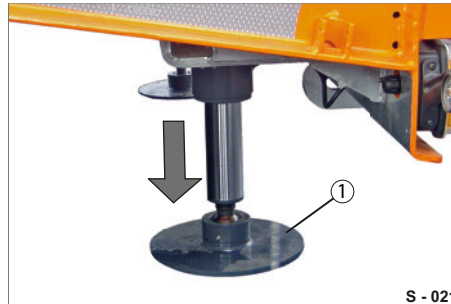

S - 021

**Abb. 21** Supports lowered

1 Leg supports at the rear

### Lower supports

- ▶ If applicable, release the support safety devices.
- ▶ Lower the supports at the rear.

### Lower the chassis frame

- ▶ If applicable, lower the vehicle frame with the lifting / lowering system.

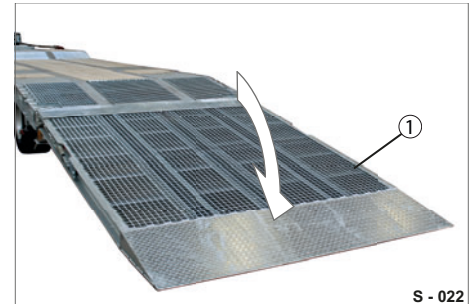

S - 022

**Abb. 22** Loading wall lowered

1 Loading wall

### Lower the loading wall and/or fold down the drive-up ramps

- ▶ Release the loading wall and/or drive-up ramps.
- ▶ Lower the loading wall and/or adjust the wheel track width for drive-up ramps and fold them down.

# 6 Pull the load / vehicle up

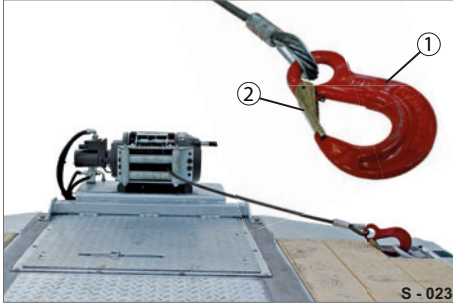

**Abb. 23** Release the slings

- 1 Hook
- 2 Safety latch

## Release the slings

- ▶ Operate the cable winch with the radio remote control:

- ▶ Press the  button.

- ▶ Press the  button.

- ▶ Press the  button.  
The cable will be relaxed.

- ▶ Press the safety latch (Abb. 23/2) in.
- ▶ Detach the sling (Abb. 23/1) from the lashing point.

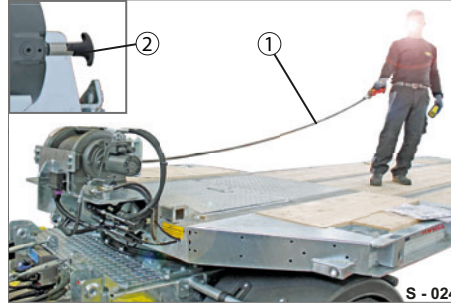

**Abb. 24** Unwind the cable

- 1 Cable
- 2 Clutch lever, latched into position

## Unwind the cable

- ▶ Check to make sure the clutch lever (Abb. 24/2) is latched into position.
- ▶ Take the hook and operate the cable winch.
- ▶ Press and hold the  button.  
The cable (Abb. 24/1) will unwind slowly.
- ▶ Guide the cable so that it will not get tangled.
- ▶ Release the button when the cable has reached a sufficient length.

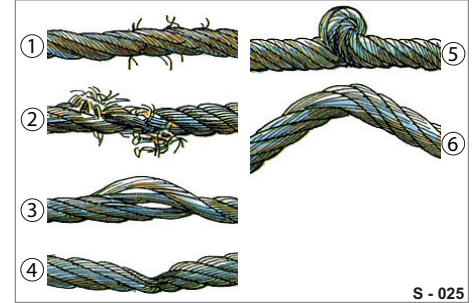

**Abb. 25** Cable damage

- 1 Cable breaks, individual
- 2 Wire breaks
- 3 Bulges
- 4 Crushing
- 5 Bends
- 6 Tangled loops

## Check cable



Never operate damaged cables or slings!

- ▶ Check the unwound cable for possible damage (Abb. 25/1-6).
- ▶ Have the damaged cable / sling replaced immediately at a specialized repair shop.



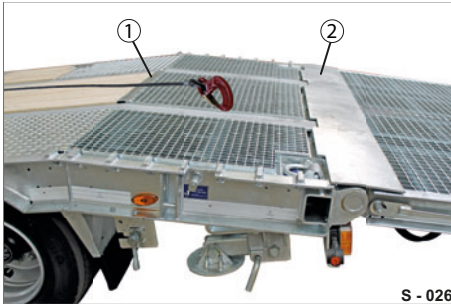

**Abb. 26** Cable guide

- 1 Protective cover
- 2 Run-on plate

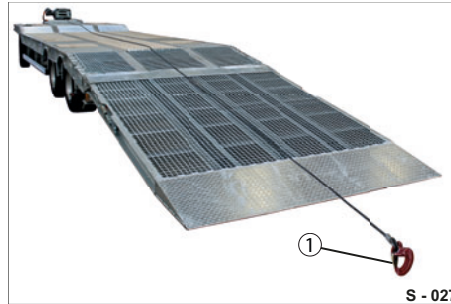

**Abb. 27** Cable extended

- 1 Slings (hooks)

### Guide the cable



Cable may be damaged by rubbing against sharp edges!

- ▶ If possible, guide the cable in the centre area of the loading surface / loading wall.
- ▶ Make sure that the cable does not get caught at an edge.

### Tie the load



The transporter is responsible for securely tying up the load with slings!

- ▶ Check to ensure that the safety latch is latched securely into the hook.
- ▶ Check to ensure that the cable / cable tie will not be deformed when force is applied.
- ▶ Stay at a safe distance to the vehicle / load.
- ▶ Keep support personnel away from the danger zone.



## Retract the cable with load

 Pulling up the load / vehicle is the most dangerous phase of the cable winch operation!

Compliance with the following important items is absolutely mandatory:

- Start the retraction process carefully and slowly.
- Never place yourself and/or support personnel on the loading surface / behind the loading surface / directly next to the loading surface. Always maintain a safe distance.
- Never try to guide the cable.
- Observe and take care of any noises that may occur during retraction. Stop the procedure immediately if the load / vehicle is pulled up unevenly and/or the load moves off to the side.
- Prevent jerking when pulling up the load. Pull up as smoothly as possible without interruptions.

- Pull the load / vehicle onto the loading surface until it can be lashed securely at the lashing points.
- Do not release the cable / sling until the load / vehicle is securely lashed.
- Lashing with the cable winch is not secure and prohibited by law. Always lash the load at the lashing points on the loading surface / vehicle frame.
- Never drive the hook / cable completely into the cable drum. Fasten the hook at a suitable point on the vehicle, e.g. lashing point.
- Make sure that the cable coils up properly in the cable drum.

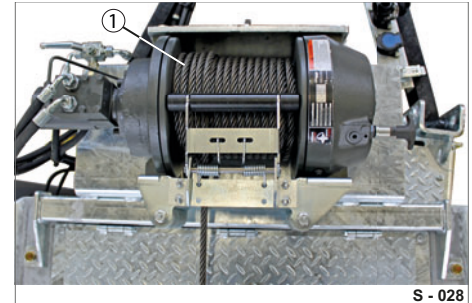

S - 028

**Abb. 28** Cable drum / cable coiled up

1 Cable coils

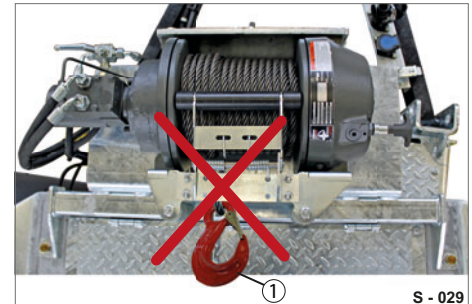

S - 029

**Abb. 29** WRONG: Hook completely pulled in

1 Hook pulled in



Abb. 30 Vehicle pulled up

- 1 Radio remote control
- 2 Cable
- 3 Slings (hooks)
- 4 Load / vehicle

### Retract cable

- ▶ Operate the cable winch with the radio remote control:

- ▶ Press the  button.

- ▶ Press the  button.

- ▶ Press the  button.  
The cable will be tensioned.

- ▶ Hold the button until the vehicle has been pulled up.



Abb. 31 Manual emergency operation

- 1 Operating lever

### Emergency support



In the event of a malfunction of the radio remote control and/or solenoid valve activation failure, the cable winch can be operated manually.

- ▶ Press the operating lever (Abb. 31/1) up at an angle.  
The cable drum will retract the cable.
- ▶ Hold the lever until the vehicle has been pulled up.



Abb. 32 Load / vehicle secured

### End the pull-up procedure



The transporter / driver is responsible for securing the load! The load / vehicle must be lashed securely!



Read the flatbed vehicle operating instructions.

- ▶ Raise the loading wall and/or fold the drive-up ramps up and secure them.
- ▶ Adjust the lifting / lowering system to the driving level.
- ▶ Raise the supports at the rear.
- ▶ Complete a departure check.

## Cleaning / maintaining cable winches



The power / compressed air and hydraulic support lines must be disconnected for cleaning and maintenance work!



Maintenance / servicing work on the cable winch may only be performed by qualified specialists in a specialist workshop!

The cleaning work depends on the use intensity and use environment or degree of cable winch contamination.

General control / maintenance work depends on the use intensity of the cable winches.

Recommendation: At least every 6 months

Maintenance work must be documented in a maintenance log.



Read and observe the safety notes and maintenance instructions in the flatbed vehicle operating instructions.

### NOTICE

#### Use of high-pressure cleaners!

Cable winches or the radio receiver or hydraulic lines may be damaged when cleaning with high-pressure cleaners.

- ▶ Exercise particular caution when cleaning the trailer with high-pressure devices.



- ▶ Do not point the water jet directly onto the cable winch / hydraulic lines / electric cables, radio receivers / valves.

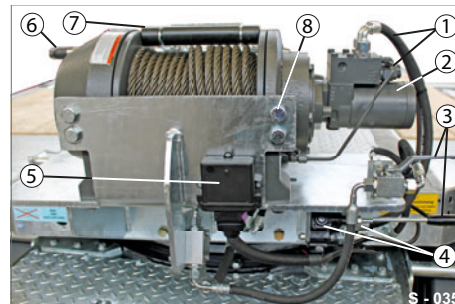

**Abb. 33** Cable winch complete  
(View from tongue)

- 1 Connections / lines
- 2 Hydraulic motor
- 3 Controls
- 4 Control valves
- 5 Radio receiver
- 6 Clutch lever, manual
- 7 Cable / cable drum / holding-down device
- 8 Screwed connection - holder

#### Visual inspection

- ▶ Carry out visual inspection of the individual components for damage / oil loss / leakage / cracks.
- ▶ If necessary, clean the individual components to remove dirt / foreign bodies / oil.
- ▶ Have defective components and any components showing signs of ageing replaced in a specialist workshop.

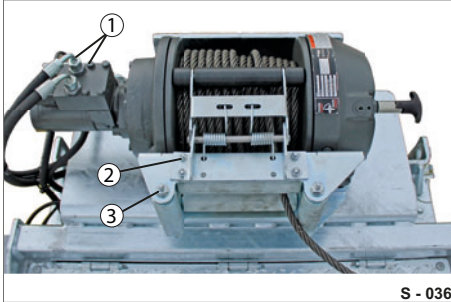

**Abb. 34** Cable winch complete  
(View from loading surface)

- 1 Screwed connection - connections
- 2 Screwed connection - holding down device
- 3 Screwed connection - guide pulleys

### Check connecting elements

- ▶ Check all connecting elements for secure fit.  
If applicable, re-tighten them.
- ▶ Have deformed connecting elements replaced immediately.

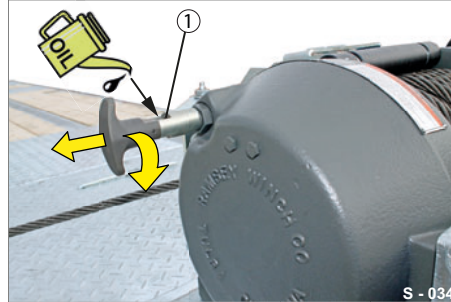

**Abb. 35** Disengage the cable drum

- 1 Clutch lever disengaged

### Lubricate clutch

- ▶ Pull and turn the clutch lever at the same time (Abb. 35/1).
- ▶ Drip a little oil onto the shaft of the clutch lever.
- ▶ Operate the clutch lever repeatedly. The oil spreads out into assembly.
- ▶ Pull the clutch lever out. The cable drum is disengaged.

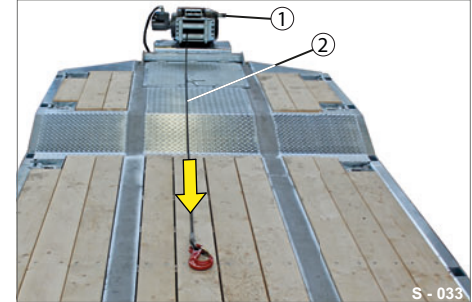

**Abb. 36** Pull the cable out manually

- 1 Clutch lever pulled out
- 2 Cable

### Clean / lubricate cable

The cable can be unwound manually when the cable drum is disengaged to perform maintenance / repair work.

- ▶ Pull the cable out.



Use

- ▶ Check the cable for damage.
- ▶ Clean the cable with a rag.
- ▶ Lubricate the entire length of the cable with grease.

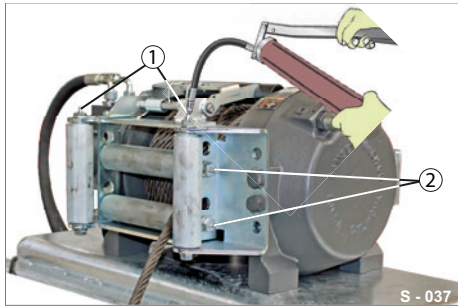

**Abb. 37** Lubricate guide pulleys  
 1 Grease nipple, top  
 2 Grease nipple, side

**Lubricate guide pulleys**

- ▶ Clean the grease nipples with a clean rag.
- ▶ Grease the guide pulleys with a grease press until grease emerges.
- ▶ Remove excess grease.

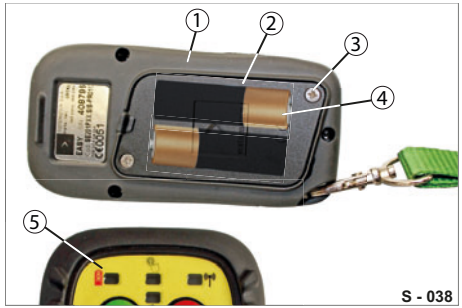

**Abb. 38** Radio remote control  
 1 Corpus  
 2 Lid  
 3 Screws  
 4 Batteries x2 (AAA Alkaline 1.5 V)  
 5 LED display for batteries

**Replace batteries**

The LED display (Abb. 38/5) indicates the state of charge of the batteries. When batteries are weak, the LED will flash "red" - when the buttons are pressed. When batteries are discharged, the LED will remain "red". The batteries must be replaced immediately because function is not guaranteed otherwise.

- ▶ Screw on the screws (Abb. 38/3).
- ▶ Remove the cover (Abb. 38/2).
- ▶ Remove the used batteries (Abb. 38/4) from the corpus (Abb. 38/1).
- ▶ Insert the 2x batteries of the same type - make sure polarity is correct.
- ▶ Insert the cover.
- ▶ Secure the cover with screws.
- ▶ Check the radio remote control for function. The LED display must flash "green" when the buttons are pressed.





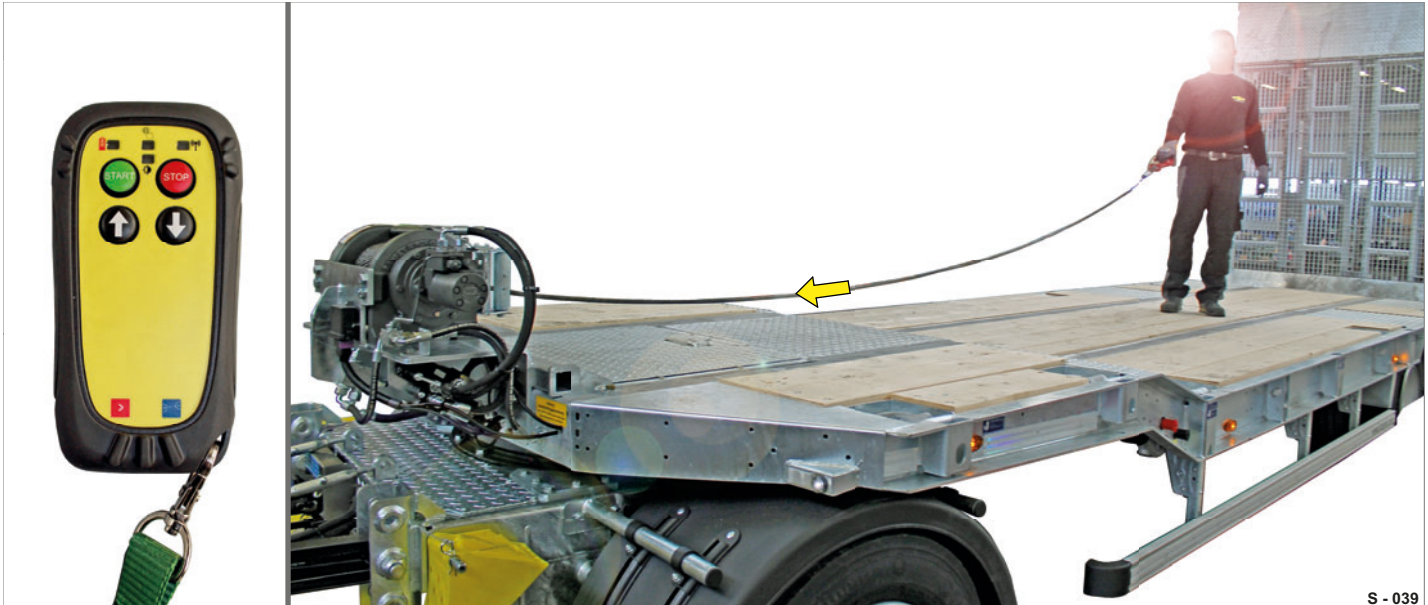

S - 039

Abb. 39 Retract cable

### Final check after cleaning / maintenance

- ▶ Connect the hydraulic / power / compressed air supply lines to the tractor.
- ▶ Switch the hydraulic line to cable winch.
- ▶ Check to make sure the clutch lever is latched into position.
- ▶ Retract the cable with the radio remote control.
- ▶ Check to ensure that the cable winds up properly on the cable drum.

Fault	Possible causes	Rectification
The cable winch is running too slow.	<ul style="list-style-type: none"> <li>- Insufficient hydraulic feed rate.</li> <li>- The hydraulic motor is used up.</li> </ul>	<p>Check the hydraulic feed rate.</p> <p>Replace the hydraulic motor in a work-shop.</p>
The cable drum does not turn - with load.	<ul style="list-style-type: none"> <li>- The maximum load capacity is exceeded.</li> <li>- The hydraulic pressure is too low.</li> </ul>	<p>Check to ensure that the nominal cable tension force has not been exceeded.</p> <p>Check the hydraulic pressure.</p>
The cable drum does not turn - without load.	<ul style="list-style-type: none"> <li>- The batteries in the radio remote control are too weak.</li> <li>- The gears are damaged.</li> </ul>	<p>Replace the batteries.</p> <p>Have the cable winch replaced in a work-shop.</p>
The cable drum does not turn - without load.	<ul style="list-style-type: none"> <li>- The gears are damaged.</li> </ul>	<p>Have the cable winch replaced in a work-shop.</p>
The cable drum does not turn freely.	<ul style="list-style-type: none"> <li>- Clutch lever not disengaged.</li> </ul>	<p>Disengage the clutch lever.</p>
The cable tangles when the clutch is disengaged.	<ul style="list-style-type: none"> <li>- Incorrect resistance screw setting.</li> </ul>	<p>Have the nylon resistance screw re-adjusted at a speciality shop.</p>
The cable winch makes loud noises.	<ul style="list-style-type: none"> <li>- The hydraulic feed rate is too high.</li> </ul>	<p>Check the hydraulic feed rate.</p>



The cable drum rattles in the direction of the retraction.	- The hydraulic feed rate is too low.	Check the hydraulic feed rate.
The cable winch loses oil from the breather (below the motor end bearing).	- The O-rings of the brake, support rings or sealing surfaces are damaged.	Have the brake removed and repaired at a speciality workshop.
The cable winch does not respond to the radio remote control.	- The batteries in the radio remote control are too weak.	Replace the batteries.
	- The receiver is damaged.	Have the receiver replaced at a speciality workshop.
	- Encoding is lost.	Re-encode the receiver and radio remote control.



Humbaur GmbH hereby confirms compliance with all relevant EC guidelines for the certification and safe operation of flatbed trailers. You can separately request an EC Declaration of Conformity from us.